



**Description:** C250-VNY-300; C250-VNY-500; 674-316; 674-470

**Area of application:**

Compatible with the surface of any carriageways of roads used for motor vehicle traffic, as well as side lanes or emergency lanes (compliant with MSZ EN 124, loading class C 250), these gully gratings shall be installed within a 0.5m-distance from the kerbside.

It ensures controlled rainwater drainage from roads or other surfaces to the channel, as well as the ventilation of the water supply system.

**Technical features:**

- The removal of the grate by unauthorised persons is not possible
- The system fixing the grate to the frame does not take part in the load bearing
- If needed, the grate can be replaced by a competent professional without removing the frame from the carriageway. Our gratings are interchangeable
- Gratings can be opened without damaging the surface of the carriageway
- Upon the request of the operator, dirt collectors fitted under the gratings are also available

Our gully gratings have a gutter-type inlet. They must be installed on the same level as those of the surface of the carriageways or the road gutter. The inlet bars must be perpendicular to the direction of traffic and must be openable in the direction of the kerbside.

Other options available to order: we can provide the gratings with any inscriptions, or firm logo requested by our client.

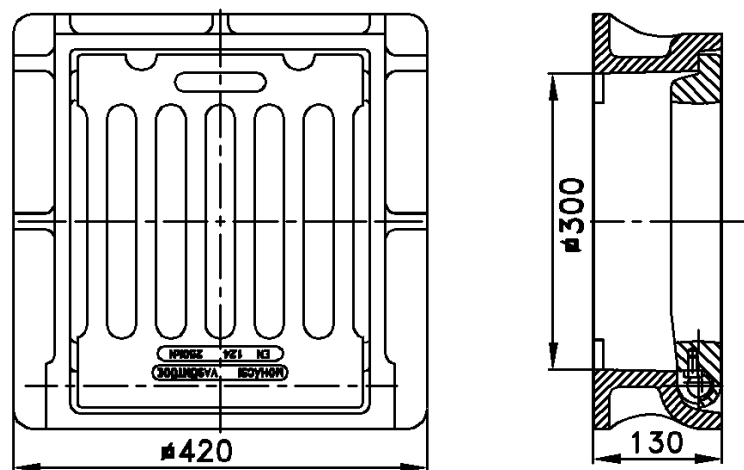

**Mohácsi Vasöntöde Kft.**