



Fire hydrant covers

Description: CSN-79; FCSSZ; 480x320

Area of application:

Suitable for covering and protecting the connection parts of underground fire hydrants connected to the public water supply system below ground level. Designed for use on public roads designated to development and any location subject to traffic up to 400 kN load resistance (40t), fixed to an appropriate concrete surface.

Technical features:

The lid is easily removable by using the hydrant wrench. Anti-slip pattern incorporated in the upper plane. Anti-theft protection provided by a chain which secures the lid to the chamber.

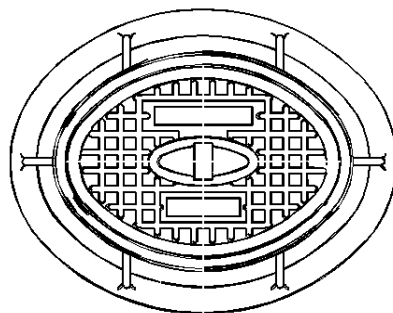
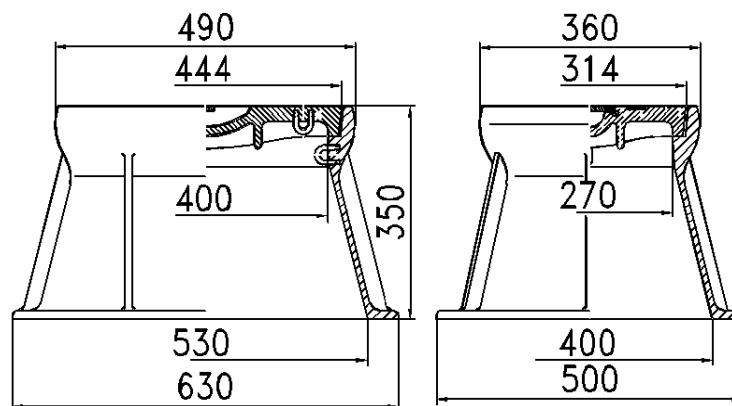

Mohácsi Vasöntöde Kft.

H-7700 Mohács, Kossuth L. u. 53-55. ■ Tel: (+36) 69 322 733 ■ Fax: (+36) 69 311 433 ■ E-mail: info@vasontode.hu

Cégjegyzékszám: 0209061982 ■ Adószám 11006536-2-02 ■ Bank: 10400779-49485050-48481000 ■ IBAN HU80 1040 0779 4948 5050 4848 1000 ■ SWIFT: OKHBHUHB