



**Description:** D400-VNY-300; D400-VNY-500

**Area of application:**

It is compatible with the surface of any carriageways of roads used for motor vehicle traffic (compliant with MSZ EN 124, loading class D 400).

It is suitable for draining rainwater from roads or other surfaces to the channel, and ensures the ventilation of the water supply system.

**Technical features:**

- Machined bearing surfaces prevent them from tilting
- The removal of the grate from the frame by unauthorised persons is not possible
- The system fixing the grate to the frame does not take part in the load bearing
- If needed, the grate can be replaced by a competent professional without removing the frame from the carriageway. Our gratings are interchangeable
- Gratings can be opened without damaging the surface of the carriageway
- Upon the request of the operator, dirt collectors fitted under the gratings are also available

Our gully gratings have a gutter-type inlet. They must be installed on the same level as those of the surface of the carriageways or the road gutter. The inlet bars must be perpendicular to the direction of traffic and must be openable in the direction of the kerbside.

Other options available to order: we can provide the gratings with any inscriptions, or firm logo requested by our client.

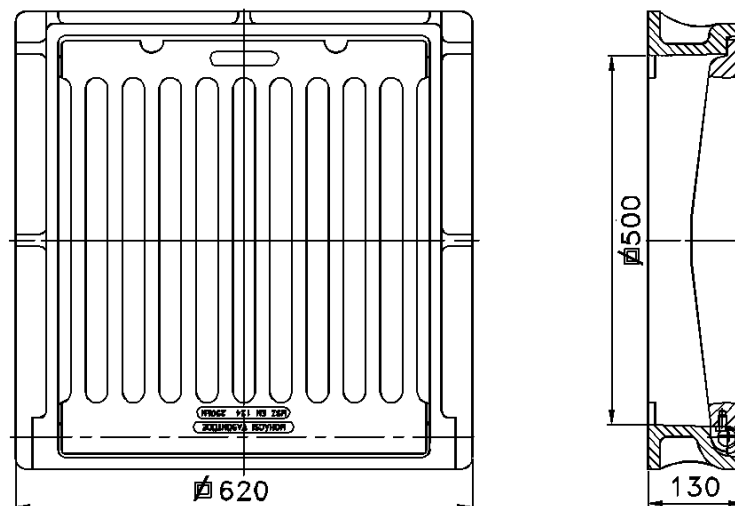

**Mohácsi Vasöntöde Kft.**

H-7700 Mohács, Kossuth L. u. 53-55. ■ Tel: (+36) 69 322 733 ■ Fax: (+36) 69 311 433 ■ E-mail: info@vasontode.hu

Cégjegyzékszám: 0209061982 ■ Adószám 11006536-2-02 ■ Bank: 10400779-49485050-48481000 ■ IBAN HU80 1040 0779 4948 5050 4848 1000 ■ SWIFT: OKHBHUHB

