



ISO 9001
QM HU 1 17 383 12
www.ecomcert.org

MOHÁCSI VASÖNTÖDE

Since 1894

www.vasontode.hu

Water meter boxes

Description: 614/A; CS-150; CS-200

Area of application:

Suitable for covering and protecting the connection parts of taps, valves, or valve extensions connected to the public water supply system below ground level.

Technical features:

The lid is easily removable by using the fitted lug. Anti-slip pattern incorporated in the upper plane. Anti-theft protection provided by screws which secure the lid to the chamber.

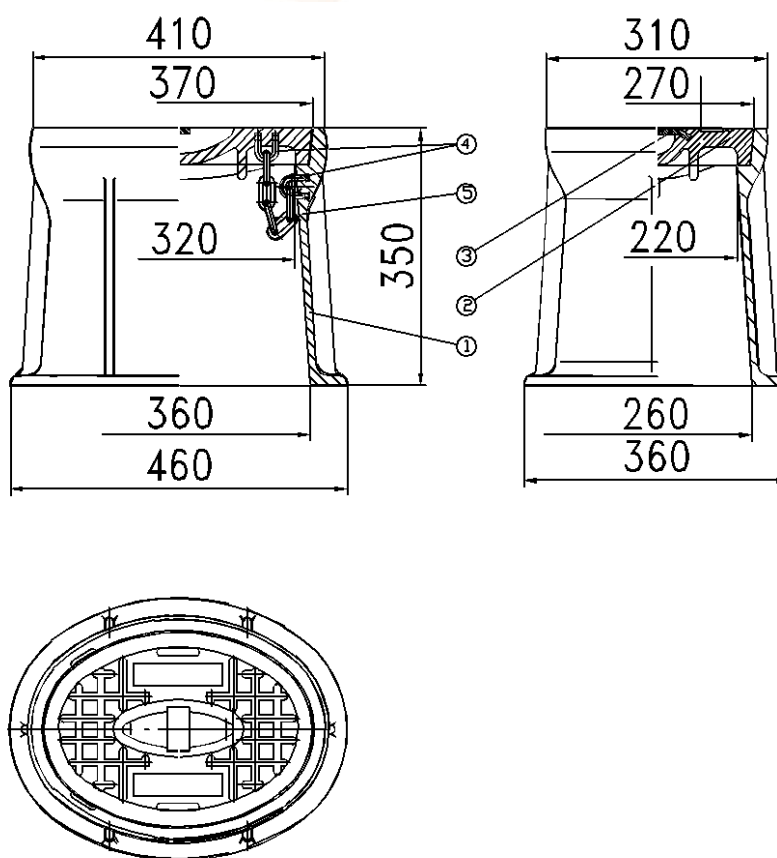

Mohácsi Vasöntöde Kft.

H-7700 Mohács, Kossuth L. u. 53-55. • Tel: (+36) 69 322 733 • Fax: (+36) 69 311 433 • E-mail: info@vasontode.hu

Cégjegyzékszám: 0209061982 • Adószám 11006536-2-02 • Bank: 10400779-49485050-48481000 • IBAN HU80 1040 0779 4948 5050 4848 1000 • SWIFT: OKHBHUHB