



ISO 9001  
QM HU 1 17 383 12  
www.ecomcert.org

**MOHÁCSI VASÖNTÖDE**

Since 1894

www.vasontode.hu

## Valve boxes

**Description:** DIN4055; DIN4056; DIN4057

### **Area of application:**

Suitable for covering and protecting the connection parts of taps, valves, or valve extensions connected to the public water supply system below ground level.

### **Technical features:**

The lid is easily removable by using the fitted lug. Anti-slip pattern incorporated in the upper plane. Anti-theft protection provided by screws which secure the lid to the chamber.

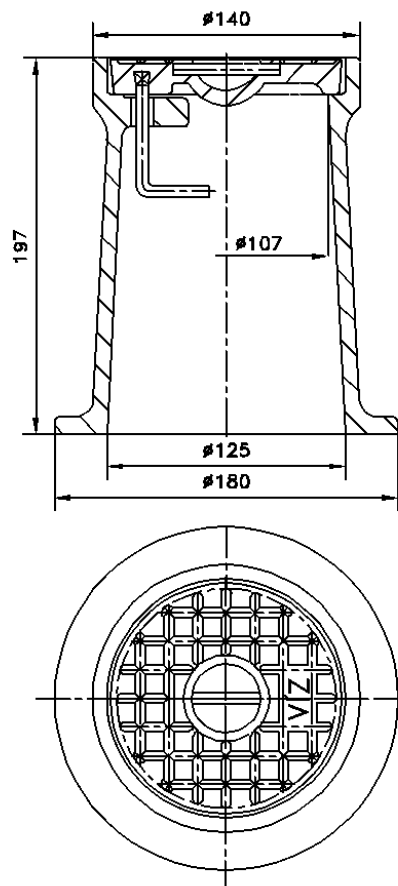

**Mohácsi Vasöntöde Kft.**

H-7700 Mohács, Kossuth L. u. 53-55. ■ Tel: (+36) 69 322 733 ■ Fax: (+36) 69 311 433 ■ E-mail: info@vasontode.hu

Cégjegyzékszám: 0209061982 ■ Adószám 11006536-2-02 ■ Bank: 10400779-49485050-48481000 ■ IBAN HU80 1040 0779 4948 5050 4848 1000 ■ SWIFT: OKHBHUHB